

All Values are Nominal

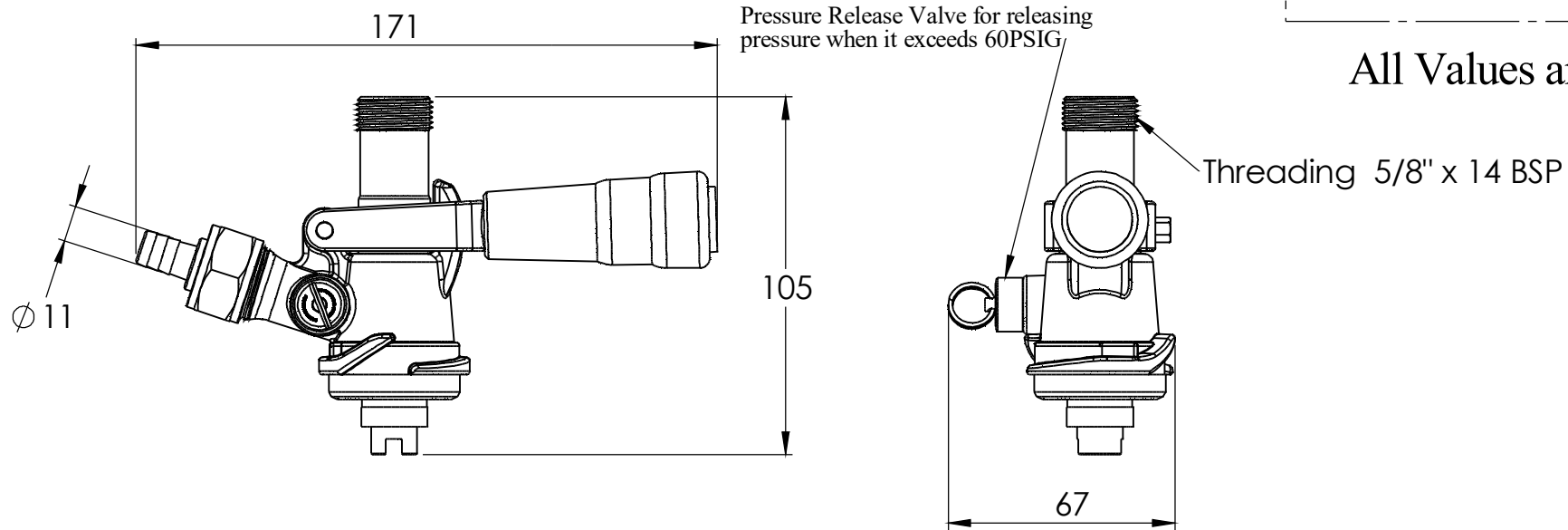

Released

Revision 01  
Revision 1

**PACIFIC**

UNLESS OTHERWISE SPECIFIED:  
DIMENSIONS ARE IN MILLIMETERS  
<sup>1.6</sup>  
SURFACE FINISH LIMIT:  $\sqrt{\text{ }}$   
TOLERANCES:  
LINEAR:  
ANGULAR:

**DIMENSIONS**

**Tolerance Dimension**

	0.5-3	>3-6	>6-30	>30-120	>120-400	>400-1000
ALL DIM. IN M.M.	±0.05	±0.05	±0.1	±0.15	±0.2	±0.3
* - IMPORTANT	±0.2	±0.3	±1	±1	±1	±1
** - CRITICAL	<±10	>±10-40	>±40-120	>±120-400	>±400	
*** - MOST CRITICAL	±1*	±0.5*	±0.2*	±0.1*	±0.5*	

The Information Contained in this drawing is the property of PACIFIC MERCHANTS and should not in any way divulged to any third party without the prior written consent of the company

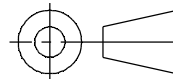

<b>DRAWN BY</b>	Daljeet Singh
<b>DATE</b>	:14-03-2018
<b>CHKD BY</b>	:KS
<b>DATE</b>	:14/03/2018
<b>APPD. BY</b>	:KS
<b>DATE</b>	:23/03/2018

<b>MATERIAL</b>	-
<b>SURFACE AREA</b>	71630.43 mm <sup>2</sup>
<b>VOLUME</b>	96497.47mm <sup>3</sup>
<b>REVISION</b>	:02
<b>FINISH</b>	-
<b>PART NO.</b>	C705Line

<b>Density</b>	0.01 g/mm <sup>3</sup>
<b>Drawing Weight</b>	587.39 g
<b>Actual Weight(g)</b>	568g

**TITLE** S System Keg Coupler Line Drawing