

**NEW BREAKTHROUGH TECHNOLOGY
GIVES NEW DIMENSIONS TO
BEER DISPENSING**

- More closer to tap
- More efficient
- Easy maintenance



C1410



- 100% stainless steel contact with beverage.
- Easy cleaning of beer lines.
- Patent pending technology.

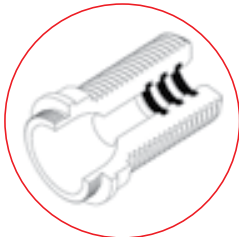

- Easy to repair by just replacing the shank.

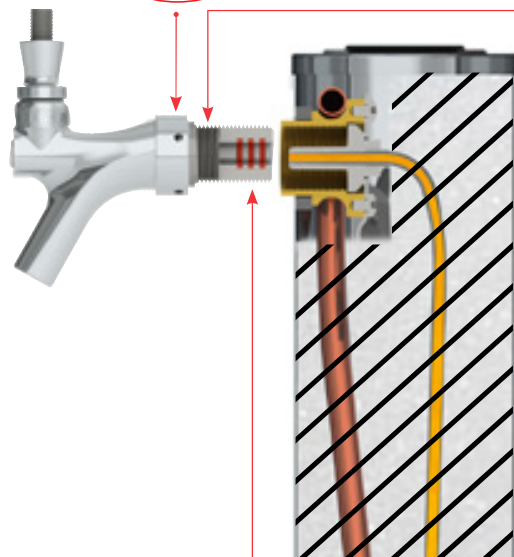

Triple layer insulation

- Aluminium foil tape.
- Black insulation tape.
- Polyurethane foam.

- Three level sealing with specially designed shank.
- Reduce maintenance cost and time in changing worn off seals by just replacing the shank
- Eliminate need for professional in case of seals worn off.
- Eliminate need for visiting dispense tower location to replace leaking cut / worn seals.



Glycol recirculation copper tubing has two point contact with cold block which is closer to shank and towards tap for quick cooling transfer.



- Specially designed brass cold block for optimum cooling at the point of dispense.
- Cold block designed for more contact with copper recirculation pipe.

